

PRODUCT DATA SHEET

DSP

Single Link Optical DVI Extension System



Revision History

| Version Number | Revision Date | Page | Description of Changes |
|----------------|---------------|---------|---|
| 1.0 | Dec.24, 2009 | ALL | Initial Version |
| 1.1 | Jul.28, 2011 | 4, 5, 6 | Supports HDCP (Rev 1.1) Extend distance (300 meter) Ordering Information (Dummy No.) Electrical Specification (Supply Current) |
| 1.1 | Feb.07, 2012 | ALL | Document Form modified |
| 1.2 | Apr. 09, 2012 | 5 | Ordering Information Removed |
| 1.3 | Oct.28, 2019 | ALL | Renewal Specification |

PROPRIETARY NOTE

****THIS DOCUMENT CONTAINS INFORMATION CONFIDENTIAL AND PROPRIETARY TO OPHIT CO.,LTD
AND SHALL NOT BE REPRODUCED OR TRANSFERRED TO OTHER DOCUMENTS OR DISCLOSED TO OTHERS
OR USED FOR ANY PURPOSE OTHER THAN THAT FOR WHICH IT WAS OBTAINED WITHOUT THE EXPRESSED
AND WRITTEN CONSENT OF OPHIT INCORPORATION***

TABLE OF CONTENTS

| | |
|---|-----------|
| 1. General Description | 4 |
| 2. General Specification | 4 |
| 3. Absolute Maximum Ratings | 5 |
| 4. Electrical Specification | 6 |
| 4.1 Electrical Specification | |
| 4.1.1 Transmitter Module | |
| 4.1.2 Receiver Module | |
| 4.2 Connector Pin Assignment | |
| 4.2.1 Transmitter | |
| 4.2.2 Receiver | |
| 5. Mechanical Specification | 8 |
| 5.1 Transmitter and Receiver Case Dimension | |
| 5.2 Connection | |
| 5.3 Optical Cable | |
| 6. Regulatory | 10 |
| 6.1 EMC & Safety Agency approval | |
| 6.1.1 CE-EMC compliance | |
| 6.1.2 FCC compliance | |
| 6.1.3 Safety | |
| 6.1.4 Eye Safety | |
| 7. Packing Information | 10 |
| 8. RoHS | 11 |
| 9. REACH | 12 |

1. General Description

DSP, optical DVI extension module, is designed to let digital flat panel display signal extend over 300 meters away from host based on DVI standard by optical transmission technology.

Its small package and transmit up to four video and one low-speed lane, while simultaneously receiving one low-speed signal, all on one multimode fiber.

- Long distance transmission of digital graphic signal corresponding to T.M.D.S over 300 meter (1,000ft) by multi-mode one fiber.
- TMDS video signals and EDID data are transmitted by 1 channel multimode optical fiber
- Maximum Supported resolution – WUXGA (1920x1200)
- Supports HDCP(Rev 1.1) by DDC channel
- Small size for insertion into internal system
- External power supply for Transmitter is optional. Automatic power switch is included

2. General Specification

| Parameter | Symbol | |
|------------------------------|---|--|
| | Transmitter | Receiver |
| Optical Converter | 850nm, 4Ch Transmit OSA 911nm, 1Ch VCSEL 980nm, 1Ch PIN P/D Diode | 850nm, 4Ch Receive OSA 980nm, 1Ch VCSEL 911nm, 1Ch PIN P/D Diode |
| Input and Output Signal | TMDS Signal (DVI 1.0 standard) | TMDS Signal (DVI 1.0 standard) |
| Video Bandwidth | 3.5Gbps / Channel | |
| Module Dimension | 39 x 14 x 61.4 mm (W x H x D) | |
| Module Weight | -- | -- |
| Used electrical Connector | 24 PIN DVI-D Plug (input) | 24 PIN DVI-D Plug (output) |
| Optical Connector | 1 SC Connector | 1 SC Connector |
| Recommended Fiber | 50/125um Multi-mode glass-fiber | |
| Maximum Supported Resolution | WUXGA(1920x1200) / 60Hz | |

3. Absolute Maximum Ratings

| Parameter | Rating |
|----------------------------|---------------------------------|
| Storage temperature | -20°C ~ +70°C Non-Condensing |
| Operating temperature | 0°C ~ +50°C Non-Condensing |
| Transportation temperature | -20°C ~ +70°C Non-Condensing |
| Power Supply | -0.3 ~ 5.5 V |
| Relative Humidity | 10 ~ 80 % |

NOTICE

Stresses greater than those listed under “Absolute Maximum Ratings” may cause permanent damage to the device. This is a stress rating only and functional operation of the device at these or any other conditions above those indicated in the operations section for extended periods of time may affect reliability.

4. Electrical Specification

4.1 Electrical Specification

4.1.1 Transmitter Module

| | Parameter | Symbol | Min | Typ | Max | Units | Condition |
|----------------------------------|---|--------------|------------------|------|------------------|----------|-----------|
| P O W E R | Supply Voltage (Option External Power) | V_{CC} | 4.5 | 5.0 | 5.5 | V | |
| | Supply Current | I_{CC} | - | 200 | 250 | mA | |
| | Power Dissipation | P_O | - | 1.00 | 1.25 | W | |
| T M D S | Reference voltage for graphic signal | V_{REF} | 3.1 | 3.3 | 3.5 | V | |
| | Single-ended high level input voltage | V_H | $V_{REF} - 0.01$ | | $V_{REF} + 0.01$ | V | |
| | Single-ended low level input voltage | V_L | $V_{REF} - 0.6$ | | $V_{REF} - 0.4$ | V | |
| | Single-ended input swing voltage | V_{ISWING} | 0.4 | | 0.6 | V | |
| | Single-ended standby input voltage | | $V_{REF} - 0.01$ | | $V_{REF} + 0.01$ | V | |
| | Data Output Load | RLD | | 50 | | Ω | |

Transmitter module of Model DSP includes 4 channel VCSEL (Vertical Surface Emitting Laser Diode) with 850, 911, 980nm invisible laser radiation.

Transmitter module of DSP is Class 1 Laser Product.

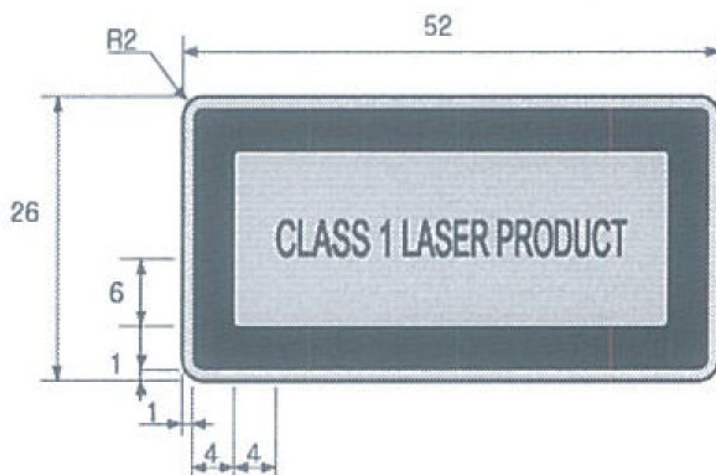

Note-Do not view directly laser module of transmitter or the end of the other side of optical cable connected to transmitter with optical instrument.

4.1.2 Receiver Module

| | Parameter | Symbol | Min | Typ | Max | Units | Condition |
|----------------------------------|---|--------------|-----|------|------|----------|-----------|
| P O W E R | Supply Voltage (External Power) | V_{CC} | 4.5 | 5.0 | 5.5 | V | |
| | Supply Current | I_{CC} | - | 170 | 220 | mA | |
| | Power Dissipation | P_O | - | 0.85 | 1.10 | W | |
| T M D S | Reference voltage for graphic signal | V_{REF} | 3.1 | 3.3 | 3.5 | V | |
| | Single-ended output swing voltage | V_{OSWING} | 0.4 | | 0.6 | V | AC couple |
| | Data Input Load | RLD | | 50 | | Ω | |

4.2 Connector Pin Assignment

4.2.1 Transmitter

| Pin | Signal Assignment | Pin | Signal Assignment | Pin | Signal Assignment |
|-----|-----------------------|-----|-----------------------|-----|-----------------------|
| 1 | T.M.D.S. Data2 - | 9 | T.M.D.S. Data1 - | 17 | T.M.D.S. Data0 - |
| 2 | T.M.D.S. Data2 + | 10 | T.M.D.S. Data1 + | 18 | T.M.D.S. Data0 + |
| 3 | T.M.D.S. Data2 Shield | 11 | T.M.D.S. Data1 Shield | 19 | T.M.D.S. Data0 Shield |
| 4 | No Connect | 12 | No Connect | 20 | No Connect |
| 5 | No Connect | 13 | No Connect | 21 | No Connect |
| 6 | DDC Clock (SCL) | 14 | +5V Power | 22 | T.M.D.S Clock Shield |
| 7 | DDC Data (SDA) | 15 | Ground (for +5V) | 23 | T.M.D.S Clock + |
| 8 | No Connect | 16 | Hot Plug Detect | 24 | T.M.D.S Clock - |

4.2.2 Receiver

| Pin | Signal Assignment | Pin | Signal Assignment | Pin | Signal Assignment |
|-----|-----------------------|-----|-----------------------|-----|-----------------------|
| 1 | T.M.D.S. Data2 - | 9 | T.M.D.S. Data1 - | 17 | T.M.D.S. Data0 - |
| 2 | T.M.D.S. Data2 + | 10 | T.M.D.S. Data1 + | 18 | T.M.D.S. Data0 + |
| 3 | T.M.D.S. Data2 Shield | 11 | T.M.D.S. Data1 Shield | 19 | T.M.D.S. Data0 Shield |
| 4 | No Connect | 12 | No Connect | 20 | No Connect |
| 5 | No Connect | 13 | No Connect | 21 | No Connect |
| 6 | DDC Clock (SCL) | 14 | Out +5V Power | 22 | T.M.D.S Clock Shield |
| 7 | DDC Data (SDA) | 15 | Ground (for Out +5V) | 23 | T.M.D.S Clock + |
| 8 | No Connect | 16 | Hot Plug Detect | 24 | T.M.D.S Clock - |

5. Mechanical Specification

5.1 Transmitter and Receiver Case Dimension

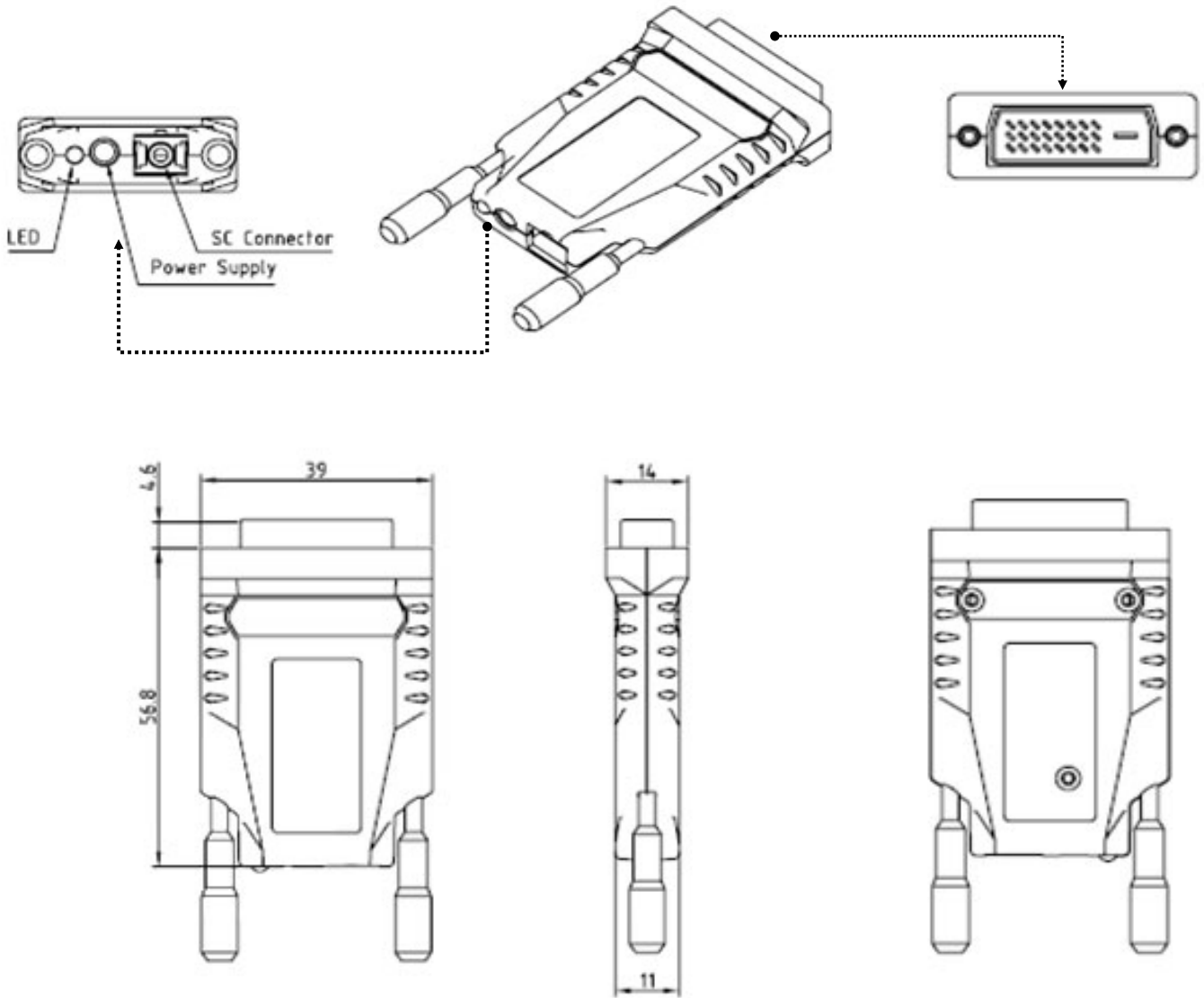

5.2 Connection

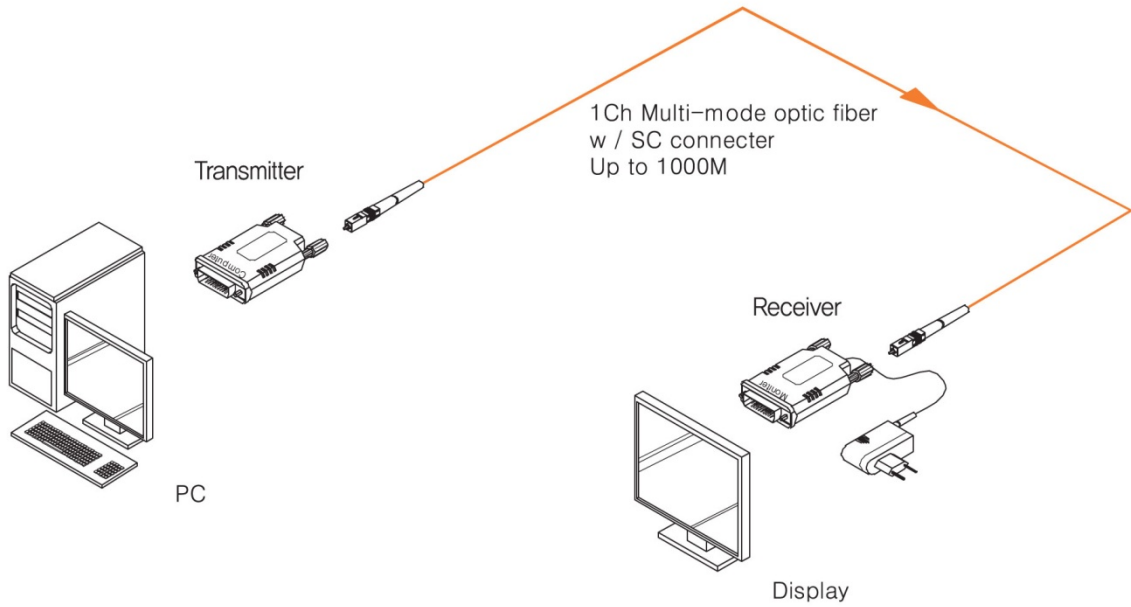

5.3 Optical Cable

- Optical Fiber Cable (MMF 50/125)

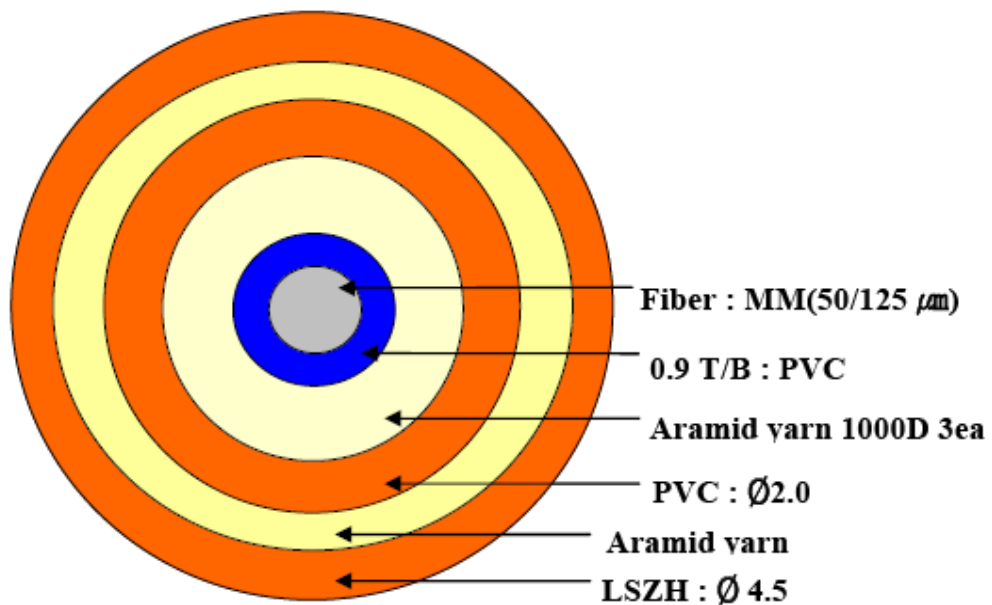
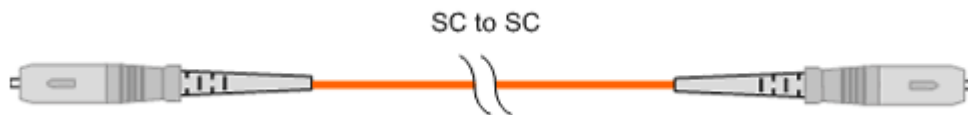

6. Regulatory

6.1 EMC & Safety Agency approval

6.1.1 CE-EMC compliance:

This Product is investigated to EN55011:2009+A1:2010, EB55032:2010, EN55024:2010 and EN61000-3-3:2009

EN60601-1-2:2007 Medical Electrical Equipment

6.1.2 FCC compliance:

This Product is investigated to FCC 47CFR part 2 and part 15

6.1.3 Safety

UL 60601-1 (Medical Electrical Equipment - Safety - Part 1: General Requirements)

CAN/CSA C22.2 No. 601.1-M90 (Medical Electrical Equipment - Safety – Part 1: General Requirements)

6.1.4 Eye Safety

CLASS 1 LASER PRODUCT-IEC60825-1:2007(2nd Edition)

7. Packing Information

| | | |
|----------------------------------|-------------------------|--------|
| Set(Unpacking, DSP Only) | 39.0mm*61.4mm*14.0mm | 43.0g |
| Package(1Set, Inner Box Packing) | 160.0mm*140.0mm*67.0mm | 358.0g |
| Package(Multi, 32PCS Packing) | 595.0mm*305.0mm*345.0mm | 12.5Kg |

8. RoHS

OPHIT is fully aware of the requirement under the **Restriction of Hazardous Substances in Electrical and Electronic Equipment Directive EU 2015/863(RoHS3)**, which adds four new restricted substances to the previous Directive 2011/65/EU(RoHS2).

Hereby we guarantee that we do not intentionally use the substances described below and based on third party chemical analysis the thresholds of the substances as indicated are not exceeded for our all products.

| Substance | CAS # | RoHS Limity by % (PPM) |
|---------------------------------------|------------|------------------------|
| Lead (PB) | 7439-92-1 | 0.1% (1000 PPM) |
| Mercury (Hg) | 7439-97-6 | 0.1% (1000 PPM) |
| Hexavalent Chromium (CrVI) | 15840-29-9 | 0.1% (1000 PPM) |
| Polybrominated Biphenyls (PBB) | - | 0.1% (1000 PPM) |
| Polybrominated Diphenyl Ethers (PBDE) | - | 0.1% (1000 PPM) |
| Cadmium (Cd) | 7440-43-9 | 0.01% (100 PPM) |
| Bis(2-Etylhexyl) phthalate(DEHP) | 117-81-7 | 0.1% (1000 PPM) |
| Benzyl butyl phthalate(BBP) | 85-68-7 | 0.1% (1000 PPM) |
| Dibutyl Phthalate(DBP) | 84-74-2 | 0.1% (1000 PPM) |
| Disobutyl Phthalate(DIBP) | 84-69-5 | 0.1% (1000 PPM) |

Banned Substances by RoHS Directive 2011/65/EU+2015/863/EU, EN50581:2012

OPHIT will continue to monitor any new amendments/changes to Directive and subsequently review our all products with regards to compliance. OPHIT will also ensure that any new information is communicated to its customers, suppliers and stakeholders as required.

Signature : Jong-Kook, Moon *Jong-kook, Moon*
Title/Issue date : President/July.22.2019

9. REACH

The European REACH Regulation 1907/2006 on Registration, Evaluation, Authorization, and Restriction of Chemicals(REACH), Annex XV II entered into Force in June 2009, and affects all companies producing, Importing, using, or placing Products on the European market. The aim of the REACH regulation is to ensure a high Level of protection of human health and the environment from chemical substances.

OPHIT Co., Ltd substances management system follow and complies with the current revision of the REACH Regulation on the substances as identified by ECHA(European Chemical Agency).

OPHIT Co., Ltd products are considered articles as defined in REACH Article 3(3). These products/articles under normal and reasonable conditions of use do not have intended release of substances. Therefore the requirement in REACH Article 7(1)(b) for registration of substances contained in these products/articles does not apply.

OPHIT Co., Ltd products/articles, do not contain **Substances of very High Concern** or if there **SVHC** in the product/article, the content is less than the 0.1%(wt/wt) as defined by REACH Article 57, Annex XIV, Directive 67/548/EEC. Therefore the requirement in REACH Article 7(2) to notify ECHA if a product/article contains more than 0.1% wt/wt of an SVHC and tonnage exceeding 1 tone per importer per year is not applicable.

OPHIT's European operations do not manufacture or import chemicals, therefore OPHIT Co., Ltd has no obligation to register substances.



Jong-Kook, Moon
President

OPHIT Co., Ltd ACCEPTS NO DUTY TO NOTIFY USERS OF THIS OF DECLARATION OF UPDATES OR CHANGES TO THIS DECLARATION.