

21.5" HD LED Medical Touchscreen Display

FS-E2101DT



Crystal Clear High Definition Images

This touchscreen medical display is ideal for manipulating images in applications that incorporate endoscopic cameras, ultrasound, cardiology, room or boom cameras, patient vital signs, and more. It displays images with near zero latency, and is compatible with major MIS camera systems in use.



User Friendly

FS-E2101DT features an intuitive, full-featured on screen menu for image and layout settings. Multi-modality options let doctors view two images at the same time. The rounded monitor housing corners help protect OR personnel from accidental bumping injuries. Its lightweight design is ideal for boom or spring-arm mounting, and the front surface is edge-to-edge glass for fast, easy cleaning.



Fingertip Control

FS-E2101DT is a projected capacitive multi-touch screen that is designed for medical applications, including complex user interfaces.

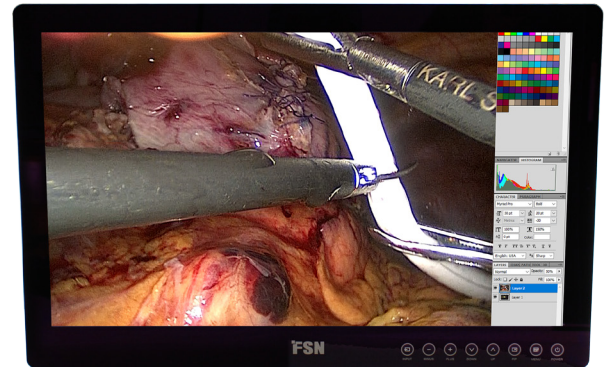

The touchscreen offers convenient data and image control for clinicians. It features a high brightness LED back light and rich color calibration for HD medical grade image consistency. Like other FSN displays, this model has a complete set of features designed for presenting images from sophisticated medical video equipment.

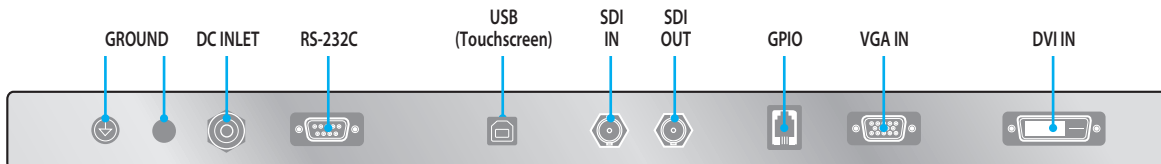
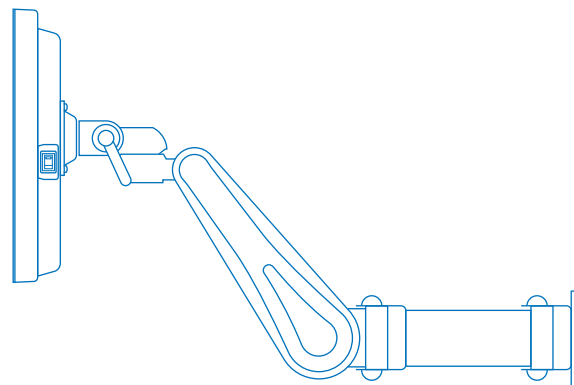
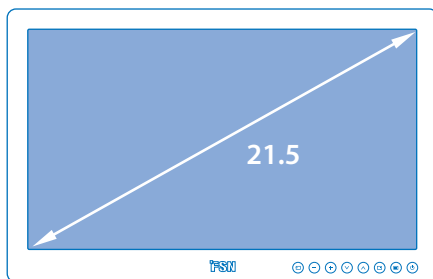

www.fsmed.com

Foreseeson Custom Displays, Inc.

2210 E. Winston Road
Anaheim, CA 92806 USA
Tel: 714-300-0540
Fax: 714-300-0546

Latin America
Aventura, FL 33180 USA
Tel: 714-507-3855

Foreseeson Korea

404B, PangyoInnovalley B
253 Pangyo-ro
Bundang-gu Seongnam-si
Gyeonggi-do, Korea 463-400
Tel: +82-31-8018-0780
Fax: +82-31-8018-0786

Foreseeson GmbH

Industriestrasse 38a
63150 Heusenstamm, Germany
Tel: +49 6104 64398 0
Fax: +49 6104 64398 11

Foreseeson UK Ltd.

Unit 71 Barwell Business Park
Leatherhead Road
Cheshington, Surrey KT9 2NY
Tel: +44 (0) 208 546 1047

Foreseeson (Shanghai)

Medical Equipment Co., Ltd.
Room 307, 3F
No. 56, 461 Hongcao Road
Caohejing Development District
Xuhui, Shanghai 200233
Tel: 86-21-6113-4188

21.5" HD LED Medical Touchscreen Display

FS-E2101DT



Specifications

General Features

Item	Description
Panel	21.5 inch TFT LCD (LED)
Resolution	1920 x 1080 pixel
Aspect Ratio	16 : 9
Active Area	476.06(H)mm x 267.79(V)mm
Touchscreen	Projected capacitive USB (2.0)
Pixel Pitch (mm)	0.2479 x 0.2479
Response Time (typical)	22 ms (rise and fall)
Number of Colors	16.7 million
Brightness (typical)	340 cd/m ²
Contrast Ratio (typical)	1000 : 1
Surface Treatment	Front side AR & AF
Viewing Angle (CR>10)	R/L 178°, U/D 178°
Input Signal	1 x DVI-D (single link) 1 x VGA 1 x SDI (SD/HD/3G)
Output Signal	1 x SDI (SD/HD/3G)
Power Supply	AC/DC Adaptor (AC 100~240V, DC 12V 5A)

Item	Description
Power Consumption	40W max
Accessories Included	User manual, AC-DC adaptor, AC power cord, DVI-D to HDMI cable, USB cable, Screw BH M4 x 14
Unit Dimension	527.9(W) x 334.5(H) x 57.9(D) mm 20.78(W) x 13.17(H) x 2.28(D) inch
Package Dimension	670(W) x 580(H) x 163(D) mm 26.38(W) x 22.83(H) x 6.41(D) inch
IP Rating	IP33 - overall, IP44 - front side only
IK Rating	IK06 with 6H AR glass
Weight	5.7 kg, 12.57 lbs. (monitor) 8.46 kg, 18.65 lbs. (shipping package)
Certifications	ANSI/AAMI ES60601-1(UL60601-1), CAN/CSA C22.2 No. 60601-1, FCC Class B, EN60601-1, EN60601-1-2, CE, MDD(93/42/EEC) Class I Medical Device

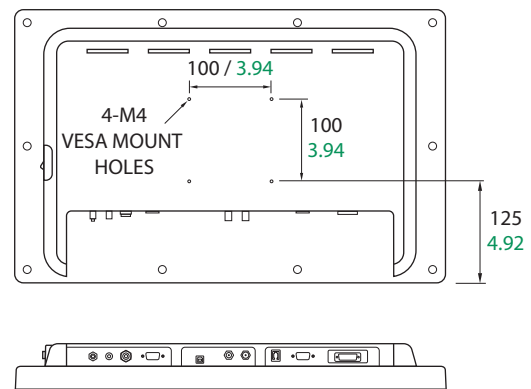
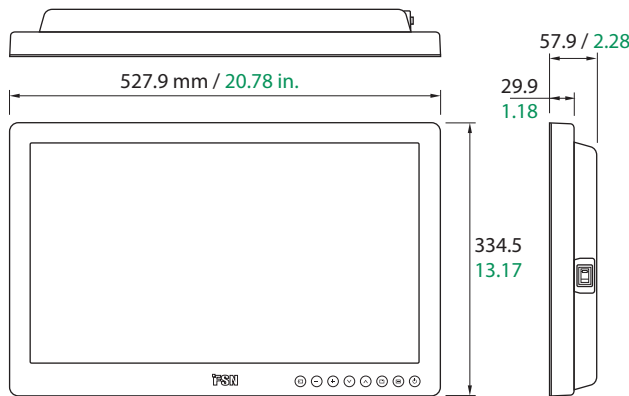

FSN Medical Technologies products meet RoHS2 and Registration, Evaluation, Authorisation and Restriction of Chemicals (REACH) obligations. FSN manages the information flow as required by regulations.

Specifications are subject to change with or without notice. Doc. # FSN2009 Rev. 2/20

www.fsnmed.com

Foreseeson Custom Displays, Inc.

2210 E. Winston Road
Anaheim, CA 92806 USA
Tel: 714-300-0540
Fax: 714-300-0546

Latin America
Aventura, FL 33180 USA
Tel: 714-507-3855

Foreseeson Korea

404B, PangyoInnovalley B
253 Pangyo-ro
Bundang-gu Seongnam-si
Gyeonggi-do, Korea 463-400
Tel: +82-31-8018-0780
Fax: +82-31-8018-0786

Foreseeson GmbH

Industriestrasse 38a
63150 Heusenstamm, Germany
Tel: +49 6104 64398 0
Fax: +49 6104 64398 11

Foreseeson UK Ltd.

Unit 71 Barwell Business Park
Leatherhead Road
Chessington, Surrey KT9 2NY
Tel: +44 (0) 208 546 1047

Foreseeson (Shanghai)

Medical Equipment Co., Ltd.
Room 307, 3F
No. 56, 461 Hongcao Road
Caohejing Development District
Xuhui, Shanghai 200233
Tel: 86-21-6113-4188